



## MVR – Salt Plants

Mechanical vapour recompression (MVR) technology enables salt producers to benefit from lower operating costs where the relative price of electricity is more attractive than that of steam. The plant design is optimized to minimise investment and operating costs.

### Highlights

- Low operating costs / high energy efficiency
- High product quality
- High condensate quality
- High environmental compatibility
- Low investment costs for boiler house
- Low building costs due to compact design and lay-out of the plant
- Low cooling water consumption
- High operational flexibility
- Easy operation / start-up / shut-down
- Long lifetime



Single-Stage Compressor



Pusher-type Centrifuge



## Typical Flow Diagram

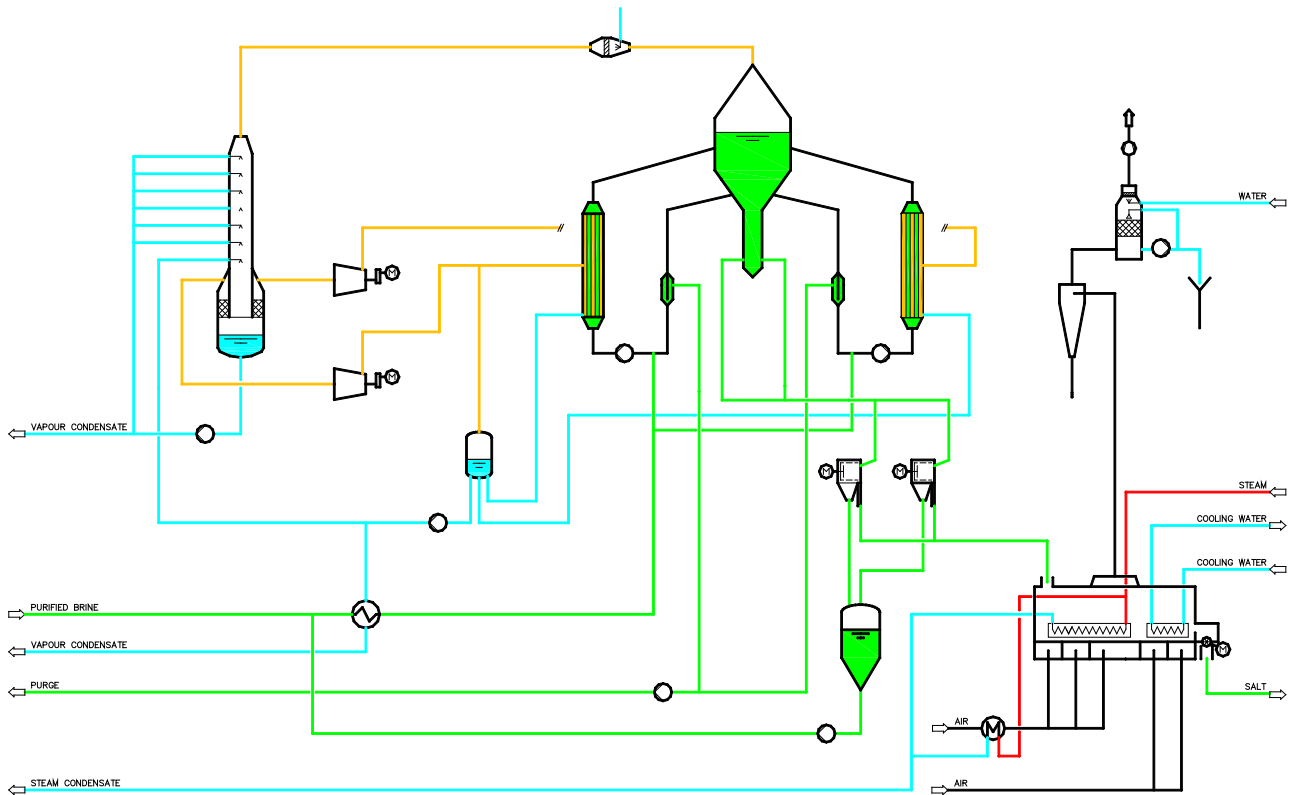

## Process Steps

- Brine preheating
- Evaporation / Crystallization
- Vapour scrubbing
- Vapour recompression
- Centrifugation
- Drying